

GENERAL DESCRIPTION

The MBT-303-A adjustable resistor divider consists of a pair of **eTC Rejistors** which allow independent, precision control of both the resistance and Temperature Coefficient of Resistance (TCR) for each resistor. Access is provided to both ends of the divider and to the center-tap. This allows control for the DC offset voltage with adjustable positive, negative or flat linear temperature response for the pair.

Independent adjustment of resistance and TCR for each resistor in the divider is accomplished by heating and cooling the resistive poly-silicon element in a closed-loop system under control of **Rejistor** Calibration tools and Rejust-it software. The output voltage adjustment range for the divider is $\pm 100\text{mV/V}$, with a temperature coefficient of output adjustment range of $\pm 150\text{ppm/K}$ (refer to Figure 4).

Adjustment is performed in-circuit to correct for offset errors and temperature induced drift on a unit-by-unit basis. Precision adjustment of the MBT-303-A is performed after temperature testing to calibrate and compensate precision analog systems.

Adjustment changes the physical properties of the resistors. No external memory or boot-up is required. The material is physically altered to have a new electrical response. After adjustment, **eTC Rejistor** dividers feature fast response to temperature and exhibit high stability.

Resistance can be matched to within 0.1%, or better, of the target value.

The divider operates from -50°C to $+150^\circ\text{C}$. The divider is ideal for precision gain setting and bridge balance circuits where set-on-test adjustment and high-precision are required.

eTC REJISTOR APPLICATIONS

- Precision resistance and temperature compensation for:
 - Sensors
 - Precision voltage references
 - Optical Components
 - Gas detectors
 - Instrumentation amplifiers
 - LCD Displays
 - Passive filters
- Replaces manual trim pots, digital pots, precision resistors and laser trimming
- Replaces temperature sensors

FEATURES

- Each Resistor is independently electrically adjustable to any value from its as-manufactured value down 30% (e.g. 30KΩ down to 21KΩ), with accuracy 0.1% or better
- Each Resistor's Temperature Coefficient is independently adjustable such that the TC of the divider output is adjustable between $+150\mu\text{V/V/K}$ and $-150\mu\text{V/V/K}$ (refer to Figure 4))
- Max voltage drop across each resistor: 6V
- Low noise: Typ. -15dB
- Passive device requires no power during operation
- Divider Power Rating up to 2.0mW at 70°C
- Operating Temperature Range -50°C to $+150^\circ\text{C}$
- In-circuit adjustable at wafer, component, board or system level
- QFN 16-pin and SOIC 8-pin RoHS, Pb-free and Green package

eTC REJISTOR BENEFITS

- Eliminates Quantization Errors and wiper resistance errors associated with digital potentiometers
- Eliminates laser trimming
- Non-Volatile "Set and Forget" adjustment. Requires no power during operation or storage
- Automated temperature compensation in the analog domain for circuits with temperature-induced error
- Null out the cumulative temperature-sensitivities of (all) other components in the system
- Adjustment system suitable for volume-production
- $y=mx+b$ generator
 - Where m is TCR
 - x is temperature
 - b is offset

FUNCTIONAL BLOCK DIAGRAM

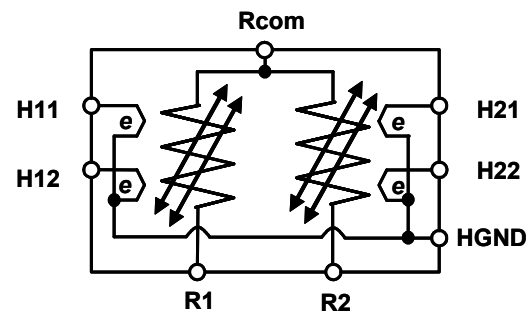

Figure 1: Functional Block Diagram. The Dual arrows represent the ability to independently adjust the resistor's ohmic value and TCR

ELECTRICAL SPECIFICATIONS

Table 1: RATINGS – *Rejutors* 0°C < T_A < +70°C; unless otherwise noted

Item	Conditions	Typical Specifications
Rated Power (per <i>Rejutor</i>)		1.0mW
Operating Temperature	As specified in this datasheet	0°C to +70°C
	As specified in Application Note " <i>Rejutor</i> Operating Guidelines for -40 to +125°C Operation"	-40 to +125°C
	Beyond -40 to +125°C	Contact Microbridge
Isolation Voltage (between any pins)	Subject to power limits	25V
Relative self-heating change in resistance	When both <i>Rejutors</i> carry the same current	<0.4%
Nominal Pair Ratio Matching	Unadjusted	±3% (e.g. 1.03 : 1.00)
Nominal Resistance	Per <i>Rejutor</i>	30,000Ω, ±10%
Nominal TC-Offset	As-manufactured	±10μV/VK
Adjustment Range		Refer to Figure 4
Offset adjustment precision	Within adjustment range, with adjustment feedback measurement directly related to divider output voltage.	±1mV/V ¹
TC-Offset adjustment precision	Within adjustment range, assuming two TC measurements (for coarse and fine adjustments), and adjustment feedback measurement directly related to divider output voltage.	±5μV/VK
Adjustment Time		1 to 5 sec ²
Thermal Time Constant	Package to die. Does not include board to package thermal delay. QFN Refer to Figure 2 SOIC Refer to Figure 3	Time to achieve 62% of final value 1.7 seconds for 100°C Temperature change 3.2 seconds for 100°C Temperature change

Table 2: RELIABILITY DATA

Characteristics	Limit	Test Method or Conditions
Thermal Shock/ Cycling	±1mV/V ³	JESD22-A104, -65°C to 125°C, 1000 cycles at 2 cycles/hour
High Temperature Exposure (long-term stability)	±1mV/V ³	JESD22-A103 150°C, 1000hrs
Humidity and Moisture Resistance	±1mV/V ³	JESD22-A101, 85% RH, 85°C, 1000hrs
Operational Life Test	±1mV/V ³	JESD22-A108, 125°C, 1000 hrs., static operation at rated power, by analysis
Shock	± 0.3mV/V	500G, 1ms duration, X,Y,Z axes each 5 shocks
Vibration, High Frequency	± 0.3mV/V	Max acceleration 20G, 20~2000~20Hz, 8 min, X,Y,Z each 4 sweeps

¹ Adjustment precision is limited by temperature control, accuracy of measurement and adjustment equipment and may increase adjustment time

² Using Microbridge's scalable production-calibration hardware (based on the NI-DAQ platform from National Instruments) and Rejust-it software, multiple units can be calibrated simultaneously during roughly the same amount of time.

³ Resistance drifts in a positive direction. Best stability is achieved at adjustments at least 10% down from the as-manufactured resistance.

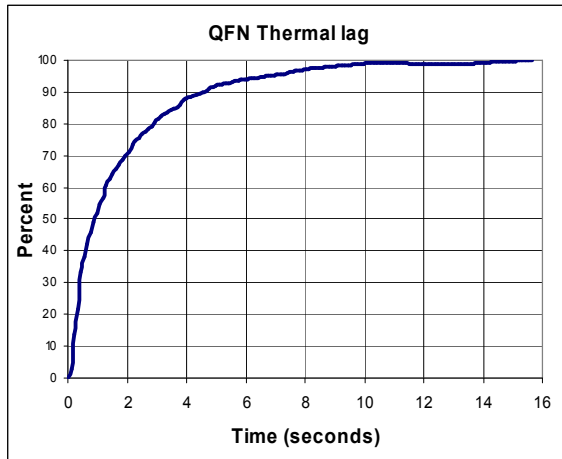

Figure 2: QFN Thermal Response Time 100°C Temperature Change

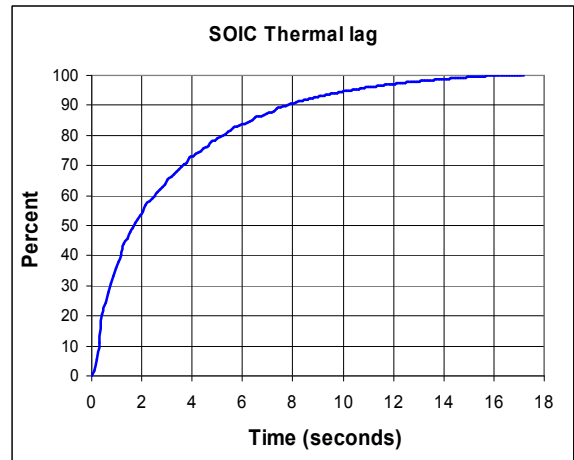

Figure 3: SOIC Thermal Response Time 100°C Temperature Change

Table 3: PACKAGE ELECTRICAL CHARACTERISTICS

Characteristics	Specification (Typical)	Test Method or Conditions
SOIC Capacitive Loading	1.0pF	Per package pin, by analysis at 100MHz
SOIC Mutual Capacitance	0.1pF	By analysis at 100MHz
QFN Capacitive Loading	0.7pF	Per package pin, by analysis at 100MHz
QFN Mutual Capacitance	0.1pF	By analysis at 100MHz

Table 4: MANUFACTURABILITY DATA

Characteristics	Test Method or Conditions
ESD Discharge	JESD22-A114, human body model weakest pin pair, all lead combinations. Class 1A
Solder ability	J-STD-020C, MSL1, 260°C convection reflow for SOIC-8 and QFN-16 packages

PACKAGING OPTIONS

Table 5: NOMINAL PACKAGE DIMENSIONS

Type	Lead Count	Body Width	Body Length	Lead Form	Tip to Tip	Body Thickness	Standoff	Overall Height	JEDEC/ EIAJ
SOIC	8	3.9mm	4.89mm	0.4mm	6.0mm	1.47mm	0.175mm	1.62mm	MS-012

Type	Lead Count	Body Width	Body Length	Lead Pitch	Lead Width	Lead Length	Body Thickness	JEDEC/ EIAJ
QFN	16	3.0mm	3.0mm	0.5mm	0.25mm	0.4mm	0.85mm	MO-220

ORDERING INFORMATION

Table 6: ORDERING INFORMATION

Part Number	Order Code	Package	Part Marking ⁴	Delivery	Quantity
MBT-303-A	112R	SOIC-8	112R-ZZZZ	Tape and Reel	3000 ⁵
MBT-303-A	112L	QFN-16	112L-ZZZZ	Tape and Reel	3000 ⁶

⁴ Where ZZZZ represents the 4-digit date code

⁵ Sample quantities are available in tubes

⁶ Smaller sample quantities available on tape

ACTIVE ADJUSTMENT RANGE

The active adjustment range is shown in the 2-dimensional plots below. Offset is defined as the deviation of the output voltage from the nominal output voltage for unadjusted *Rejustors*. For a 1:1 divider, the nominal output voltage is $\frac{V_{in}}{2}$.

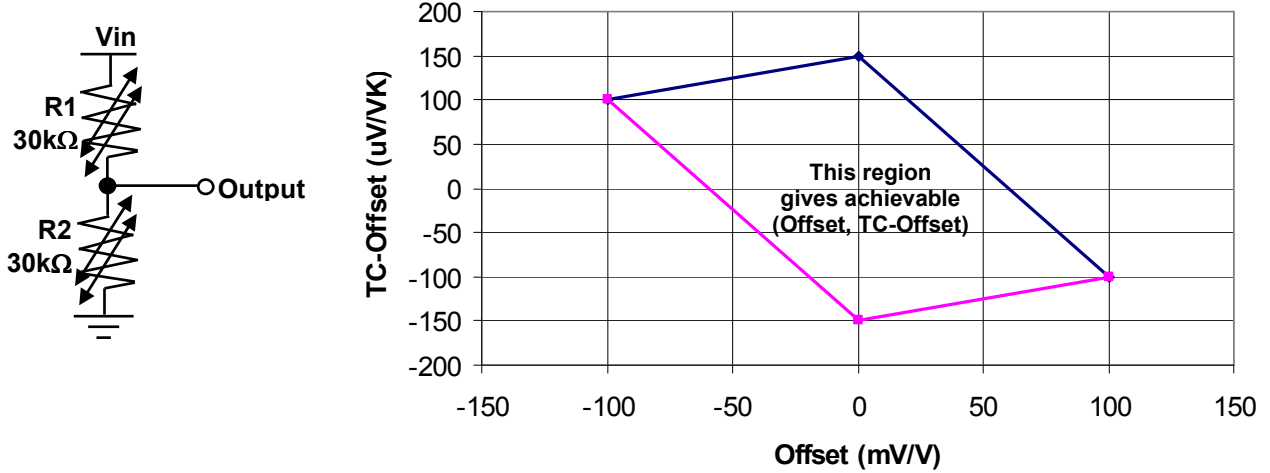

Figure 4: Divider: Region of achievable values (Offset and TC-Offset) from Nominal

ADJUSTED eTC REJUSTOR EXAMPLES

The chart in Figure 5 provides several examples of the output offset and temperature response that can be achieved with the *eTC Rejustor* divider. An infinite number of combinations are achievable with the same *Rejustor* divider adjusted to different output parameters including the five examples shown below. Output offset voltage is shown as a function of temperature where the initial offset is specified at 10°C.

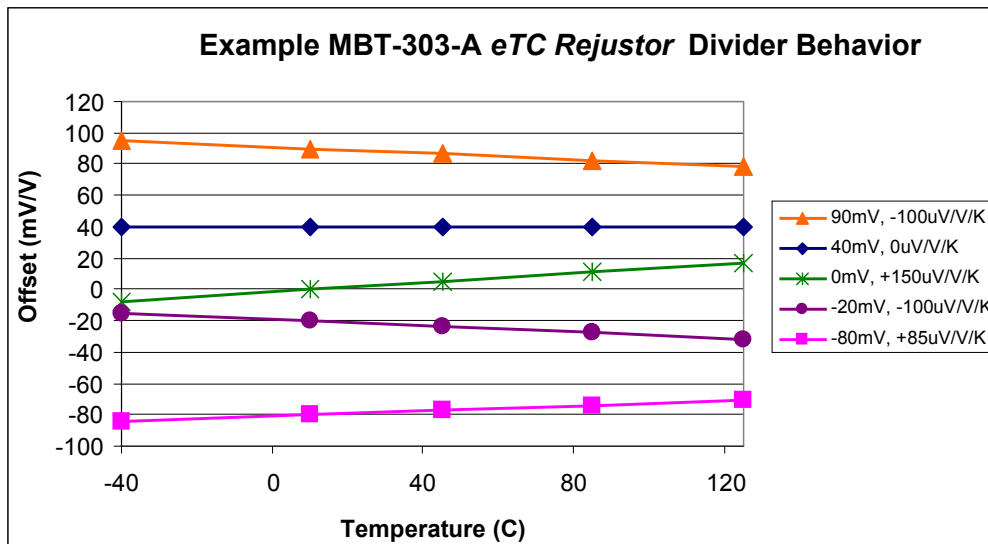

Figure 5: Example *eTC Rejustor* Divider Response

APPLICATION EXAMPLES

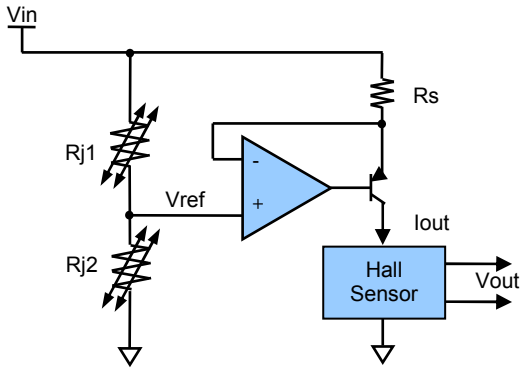

Figure 6: Hall-effect Sensor Application Circuit

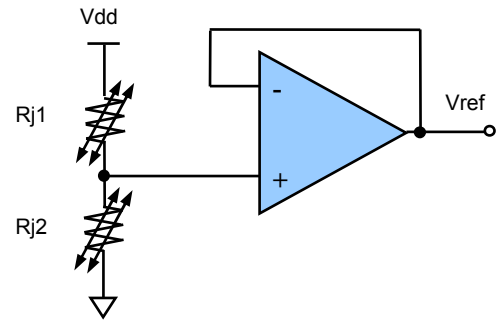

Figure 7: Temperature Compensated Reference

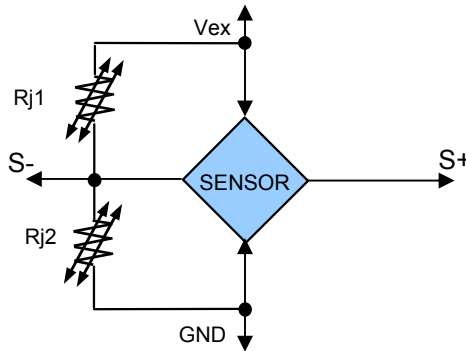

Figure 8: Simple eTC Rejistor Compensation for a Wheatstone Bridge Sensor

FUNCTIONAL DESCRIPTION

Microbridge **Rejutors** with **eTC** represent a technology revolution in adjustment and temperature compensation for precision electronic systems. Each **Rejutor** within the divider allows independent, precision adjustment of resistance and temperature response. The **eTC Rejutor** Divider responds as described in the 2-dimensional diagram in Figure 4 when configured as a voltage divider.

An **eTC Rejutor** divider allows adjustment of the divider output voltage away from its initial output voltage (“Offset” in mV per Volt applied to the top of the divider), and at the same time allows independent adjustment of the temperature coefficient of the output voltage (“TC-Offset” in μV per degree Kelvin per volt applied to the divider). In this way, a temperature-conditioned voltage divider is obtained.

eTC Rejutor dividers can be adjusted in-circuit to generate a resistance ratio and temperature profile to compensate temperature and offset sensitive devices. The resistance of each **eTC Rejutor** is adjusted to correct for manufacturing variance in the uncompensated circuit. In addition, the **Rejutor's** temperature response is adjusted to counteract the temperature coefficients of the uncompensated circuit. In other words the **Rejutor** is adjusted in-circuit to compensate for offset and cumulative temperature drift of all the components within the circuit.

eTC Rejutor dividers are used in-circuit in places where offset and temperature drift correction are required. The application examples, above, demonstrate samples where the output from the divider controls the performance of the overall circuit. During the calibration process, the **eTC Rejutor** divider is connected to the low-cost MBK-408A **Rejutor** Calibration Tool, or equivalent hardware⁷. The Calibration tool provides the electrical connections to monitor the circuit output behavior and drive power into the auxiliary pins of the **Rejutor**. Power applied to the auxiliary pins controls the heating and cooling process which in-turn changes the resistance and TCR of the divider. Refer to Figure 9 for a sample connection between the calibration tool and the MBT-303-A. Connection to the calibration tool is only required during adjustment.

⁷ Using Microbridge’s scalable production-calibration hardware (based on the NI-DAQ platform from National Instruments) and Rejust-it software, multiple units can be calibrated simultaneously during roughly the same amount of time for high-volume applications.

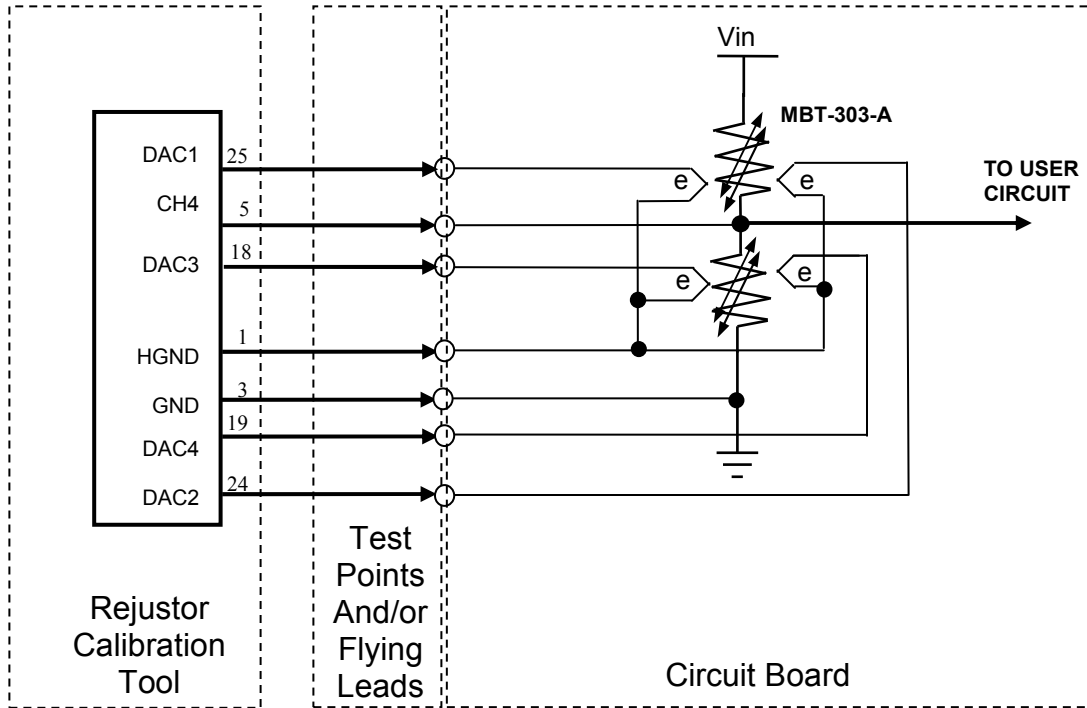

Figure 9: Rejistor Hardware Connection

Rejust-it software, provided with the **Rejistor** Calibration Tool as LabVIEW-based executable, controls the adjustment process using the **Rejistor** Calibration Tool in a closed-loop feedback system. **Rejistors** are automatically adjusted to the target offset and TCR values, as specified. Typically the overall drift of the circuit is measure (using two data points; cool and hot) and entered into Rejust-it. The **Rejistor** Calibration tool measures the offset prior to adjustment. Normally the targets are 0 offset and 0 TC-Offset (although different targets are also valid). A 1-5-second sequence of electrical heating pulses, governed by Microbridge’s proprietary algorithms, is enough to fine-tune the material properties.

After adjustment, the circuit is disconnected from the **Rejistor** Calibration tool. The **Rejistor** does not require active power to maintain its adjusted resistance and TCR. The material properties of the **Rejistor** are altered to affect the current flow, which means the resistance is changed. **eTC Rejistors** are intended for set-and-forget applications that involve factory calibration. The devices can be adjusted dozens-of-times, as required for periodic maintenance.

The resistive element is electrically isolated from both substrate and auxiliary (heater) pins and can therefore float, electrically.

Compensated **eTC Rejistors** are highly stable and provide fast temperature response. Once adjusted, **eTC Rejistors** retain their electrical and temperature performance characteristics indefinitely. **Rejistors** can be adjusted many times, bi-directionally without compromising stability or performance.

Microbridge **Rejistors** are an electrical replacement for mechanical compensation techniques. They replace manual trim pots, digital pots and laser trimming. **eTC Rejistors** replace compensation techniques using metals, such as aluminum, to provide temperature compensation. The Microbridge Technologies **eTC Rejistor** family of electrically adjustable micro-resistors can be matched to values for precision control of sensors, voltage regulators, amplifiers and other applications.

eTC Rejistor Dividers are available in compact QFN 16-pin and SOIC 8-pin packages.

PIN CONFIGURATION

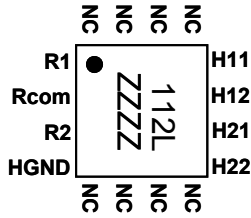

**Figure 10: Pin-out
16-lead QFN package**

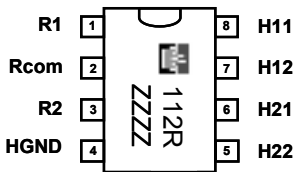

**Figure 11: Pin-out
8-pin SOIC package**

PIN FUNCTIONAL DESCRIPTIONS

Table 7: MBT-303-A Pin Function Descriptions

Mnemonic	Description	eTC Rejistor QFN Pin No.	eTC Rejistor SOIC Pin No.
R1	Rejistor 1 Terminal	1	1
Rcom	Rejistor Divider Center	2	2
R2	Rejistor 2 Terminal	3	3
HGND	Adjustment Ground	4	4
H22	Rejistor 2 Adjustment Input 2	9	5
H21	Rejistor 2 Adjustment Input 1	10	6
H12	Rejistor 1 Adjustment Input 2	11	7
H11	Rejistor 1 Adjustment Input 1	12	8
NC	No connect	5, 6, 7, 8, 13, 14, 15, 16	

Note: QFN Package – Ground Pad is not connected.

PACKAGING INFORMATION

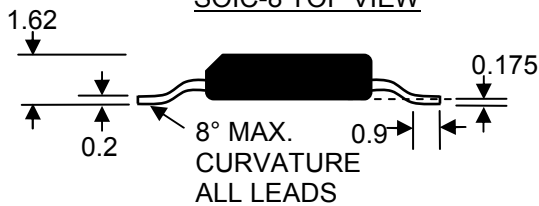
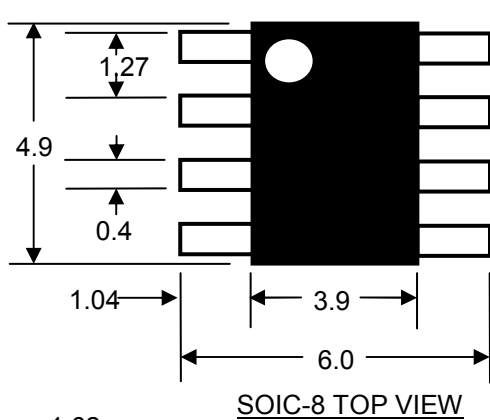

SOIC-8 SIDE VIEW

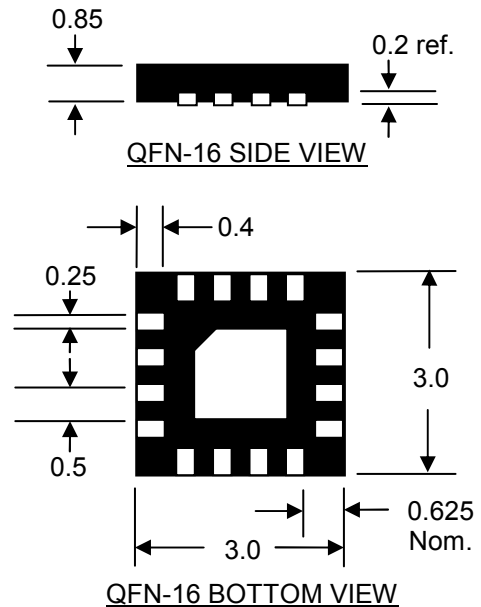

All dimensions in millimeters

Figure 12: Package Dimensions

TAPE CARRIER PACKAGING

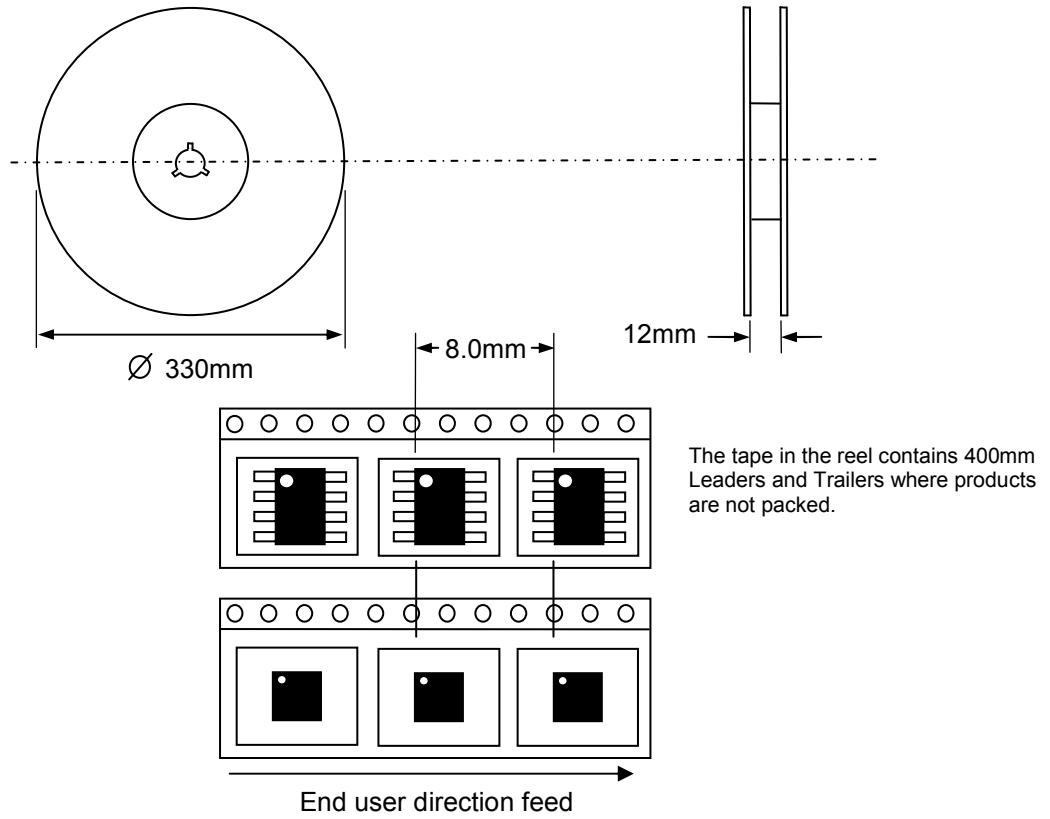

Figure 13: Tape Carrier Dimensions

Please check with Microbridge Technologies Inc prior to design to ensure you have the latest revision of the datasheet for this part.