

MB-LPS1-01-XXXX5R Series Linear Analog-Conditioned Sensors For Low Differential Air Pressure (5V Supply, Ratiometric)

GENERAL DESCRIPTION

The MB-LPS1-01-XXXX5R series low-pressure sensors sense differential air pressure (or other non-corrosive gas pressure), inferring differential pressure from nano-liters per second gas-flow through an integrated air-flow channel having high flow-impedance. The transducer is a MEMS-based thermo-anemometer on a monolithic silicon chip. Rejistor technology combined with CMOS circuitry provides on-chip-integrated analog-only compensation and conditioning electronics. The chips are powered by 5V supply, with ratiometric output voltage between 0.5V and 4.5V.

FEATURES, BENEFITS

- **Linear output**
- **Small size, small footprint**
- **High flow-impedance in the range of tens to hundreds of kPa/(ml/s)**
 - Dominates flow-impedance in series (in-line) configurations.
 - Minimizes flow-through in bypass (parallel, shunt) configurations.
 - Allows use of filters and connection hoses without losing calibration.
 - Establishes excellent resistance to dust/humidity contamination
- Rejistor-based analog-only on-chip signal conditioning electronics to compensate (Offset, TC-Offset, Span, TC-Span).

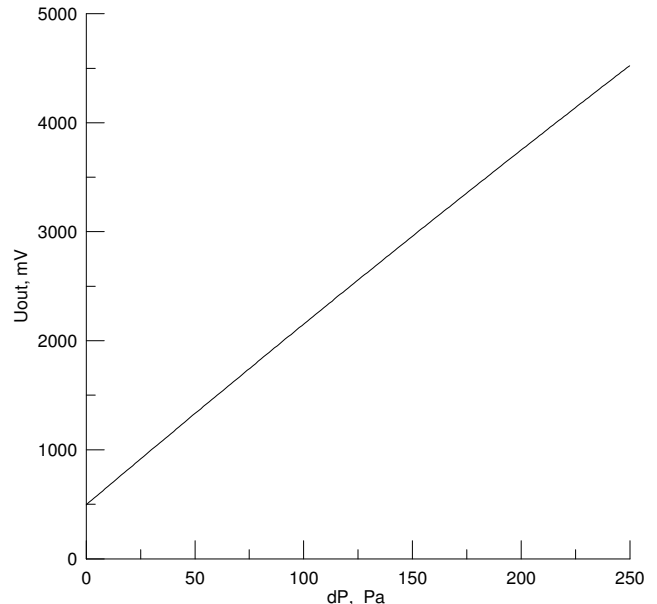

Fig. 1: Typical linear response for MB-LPS1-01 series sensor.
Example: MB-LPS1-01-100U5R → 1”H₂O, unidirectional.

PRODUCT FAMILY:

MB-LPS1-01-XXXX5R, FOR APPLICATIONS SUCH AS HVAC, REQUIRING LINEAR OUTPUT:

Unit ID	Measurement Range** (Full Scale)			Pneumatic Flow-Through Impedance
MB-LPS1-01-010B5R	+/-25Pa	+/-0.1”H ₂ O	+/-0.0036PSI	>10kPa/(ml/s)
MB-LPS1-01-010U5R	0...25Pa	0...0.1”H ₂ O	0...0.0036PSI	>10kPa/(ml/s)
MB-LPS1-01-020B5R	+/-50Pa	+/-0.2”H ₂ O	+/-0.0072PSI	>15kPa/(ml/s)
MB-LPS1-01-020U5R	0...50Pa	0...0.2”H ₂ O	0...0.0072PSI	>15kPa/(ml/s)
MB-LPS1-01-050B5R	+/-125Pa	+/-0.5”H ₂ O	+/-0.018PSI	>20kPa/(ml/s)
MB-LPS1-01-050U5R	0...125Pa	0...0.5”H ₂ O	0...0.018PSI	>20kPa/(ml/s)
MB-LPS1-01-100B5R	+/-250Pa	+/-1”H ₂ O	+/-0.036PSI	>40kPa/(ml/s)
MB-LPS1-01-100U5R	0...250Pa	0...1”H ₂ O	0...0.036PSI	>40kPa/(ml/s)
MB-LPS1-01-200B5R	+/-500Pa	+/-2”H ₂ O	+/-0.072PSI	>80kPa/(ml/s)
MB-LPS1-01-200U5R	0...500Pa	0...2”H ₂ O	0...0.072PSI	>80kPa/(ml/s)

- ** Note: 250Pa = 1.005433”H₂O, which is approximated in this table as 1”H₂O and 0.036PSI. These sensors are calibrated at room temperature according to the number of Pa stated in this table.
- For other full-scale ranges, or asymmetrical full-scale ranges, or alternate temperature ranges, contact Microbridge.
- Custom units available on request.
- www.mbridgetech.com

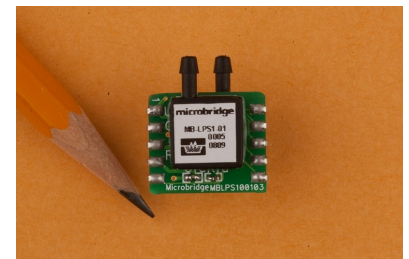

Information furnished by Microbridge Technologies is believed to be accurate and reliable. However, no responsibility is assumed by Microbridge Technologies for its use, nor for any infringements of patents or other rights of third parties that may result from its use. Specifications subject to change without notice. No license is granted by implication or otherwise under any patent or patent rights of Microbridge Technologies. Trademarks and registered trademarks are the property of their respective companies.

**TABLE 1: MB-LPS1-01-XXXX5R SPECIFICATIONS:
LINEAR ANALOG-CONDITIONED LOW DIFFERENTIAL AIR PRESSURE SENSOR**

Characteristic	Specification
Temperature Ranges	Compensated: +5°C to +55°C Compensated (relaxed specifications, see below): 0°C to +70°C Operating: -20°C to +80°C Storage: -40°C to +80°C
Humidity	0 to 85%RH (non-condensing)
Supply Voltage (V _{DD})	V _{DD} = 5 VDC (min 4.75V, max 5.25V)
Current Consumption	Typ. 3.7 mA (no load)
Output Impedance	Max less than 100Ω
Minimum output load resistance	5kΩ (less than 1 mA output drive current).
Nominal output voltage (with V _{DD} = 5 VDC)	MB-LPS1-01-XXXU5R: 0.5V (at zero-Pressure); 4.5V (at Full-Scale Pressure) MB-LPS1-01-XXXB5R: 0.5V (at Negative Full-Scale Pressure); 2.5V (at zero-Pressure); 4.5V (at Positive Full-Scale Pressure). Output Voltage is ratiometric with Supply Voltage.
Nominal full-scale voltage span (with V _{DD} = 5 VDC)	MB-LPS1-01-XXXU5R: +4V MB-LPS1-01-XXXB5R: +/-2V (2V). Full-scale voltage span is ratiometric with Supply Voltage.
Calibrated Offset Tolerance	less than +/-25mV
Offset Temperature Shift	less than +/-25mV (5°C to 55°C) less than +/-40mV (0°C to 70°C)
Offset Warmup Shift	less than +/-5mV (1h of operation)
Offset Repeatability (incl hysteresis, not incl warmup)	Typ. +/-1mV (less than noise) Max. +/-5mV (repeated measurement during 1hr at constant barometric P)
Pressure Non-Linearity	less than +/-1.5% of Full-Scale (by best-fit-straight-line method)
Differential Pressure Resolution	Typ. 0.1% of Full-Scale (minimum detectable differential pressure, with recommended output filtering – see below)
Sensitivity Shift Over Temperature	Typ. +/-1%, Max +/-1.5% (5°C to 55°C) Typ. +/-1.5%, Max +/-2.25% (0°C to 70°C)
Repeatability of Sensitivity (incl hysteresis, not incl warmup)	Typ. +/-0.1% Max. +/-0.5% (repeated measurement during 1hr at constant barometric P)
Response Time	Typ. 1-2ms (time constant of exponential response to a pressure step)
Total Error (not including Long-Term Stability)	Max. +/-3.0% of Full-Scale (5°C to 55°C) Max. +/-5.0% of Full-Scale (0°C to 70°C)
Long Term Stability	Max +/-1.5% of Full-Scale (based on powered operation at 85°C for 120hrs)
Burst Pressure	Greater than 5 atmospheres
ESD protection	2000V HBM – JESD22-A114, human body model weakest pin pair testing, all lead combinations, Class 2.
RoHS compliant	

IMMUNITY TO RFI:

Test	Result
Sweep 80MHz - 2.7GHz	<ul style="list-style-type: none"> Less than 0.5% error for any package orientation subjected to 10V/m electric field (by analysis).

Information furnished by Microbridge Technologies is believed to be accurate and reliable. However, no responsibility is assumed by Microbridge Technologies for its use, nor for any infringements of patents or other rights of third parties that may result from its use. Specifications subject to change without notice. No license is granted by implication or otherwise under any patent or patent rights of Microbridge Technologies. Trademarks and registered trademarks are the property of their respective companies.

PACKAGE AND PINOUT INFORMATION:

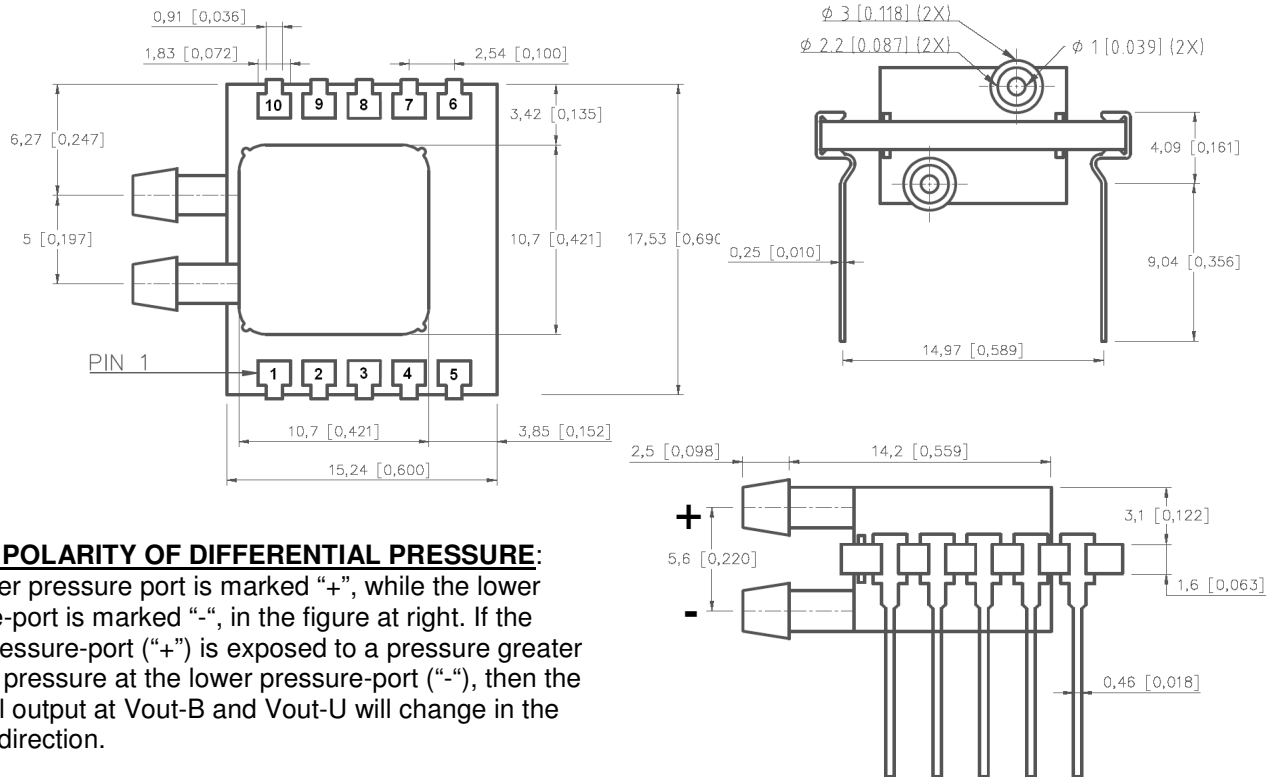

ABOUT POLARITY OF DIFFERENTIAL PRESSURE:

The upper pressure port is marked "+", while the lower pressure-port is marked "-", in the figure at right. If the upper pressure-port ("+") is exposed to a pressure greater than the pressure at the lower pressure-port ("-"), then the electrical output at Vout-B and Vout-U will change in the positive direction.

Pin #	Name	Function
1	GND	Main circuit ground for the power supply and analog circuit
2	VDD	Main circuit power supply
3	Vout-B	Output voltage for bidirectional-mode sensors (calibrated in MB-LPS1-01-XXXB5R units)
4	Vout-U	Output voltage for unidirectional-mode sensors (calibrated in MB-LPS1-01-XXXU5R units)
		Note: A subset of the above pins are the only pins used during normal functioning of the sensor (GND, VDD and <i>either</i> Vout-B <i>or</i> Vout-U). Note that <i>either</i> Vout-B <i>or</i> Vout-U provides a calibrated output, not both.
5		Should be connected to ground by the user.
6		Should be connected to ground by the user.
7		Should be connected to ground by the user.
8		Should be connected to ground by the user.
9		Should be connected to ground by the user.
10		Should be connected to ground by the user.
		Note: pins # 5 – 10 should be connected to ground by the user, but no current will be flowing through them in normal operation. These pins are not all connected to each other internally.

Information furnished by Microbridge Technologies is believed to be accurate and reliable. However, no responsibility is assumed by Microbridge Technologies for its use, nor for any infringements of patents or other rights of third parties that may result from its use. Specifications subject to change without notice. No license is granted by implication or otherwise under any patent or patent rights of Microbridge Technologies. Trademarks and registered trademarks are the property of their respective companies.

RECOMMENDED OUTPUT VOLTAGE FILTERING:

It is recommended for normal usage that the output of the sensor be connected through an RC low-pass filter as shown in the circuit diagram below. The choice of low-pass cutoff frequency can be made according to the desired response-time.

Note that this filter is connected during calibration of the sensors, with $R_{filter} \sim 5k\Omega$ and $C_{filter} \sim 100nF$.

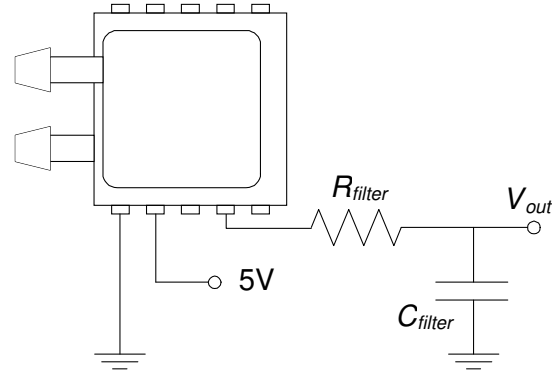

STANDARD ALTITUDE CORRECTION:

Variations in ambient atmospheric pressure (caused by elevation with respect to sea level), need to be compensated externally to the sensor, according to a simple mathematical expression:

$$\rightarrow [(True-\Delta P)] = [(Sensor-\Delta P) \times (1.00 \text{ bar}) / (Ambient-Pabs)]$$

where:

True- ΔP : altitude-adjusted differential pressure

Sensor- ΔP : sensor's differential pressure as indicated by the output voltage

Ambient-Pabs : actual ambient absolute pressure (measured in bars)

Note: Units are calibrated such that True- ΔP will equal the Sensor- ΔP when the ambient pressure is 1.00 bar.

PART NUMBER NAMING CONVENTION:

MB - LPS 1 - 01 - 100 B 5 R

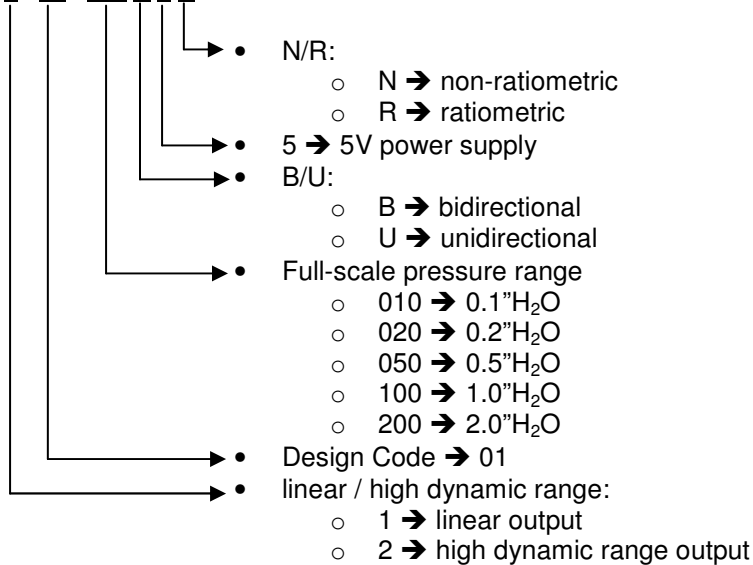

REVISION HISTORY:

- Beginning with: Rev. 3.03, February 02, 2010.
- Rev. 4.01, September 27, 2010: The Table on p.3 has been changed, to reflect the new requirement that pins 5-10 should be grounded by the user. A note regarding Vout-B and Vout-U has been added. A 0.5" H₂O sensor has been added. Flow impedance tolerances have been widened. Temperature ranges have been added. Table 1 on p.2 has been enhanced with several added and changed specifications. Several cosmetic changes have been made.
- Rev. 4.02, January 20, 2011: An error in the Product Family Table on p.1 has been corrected: MB-LPS1-01-050U5N is corrected.

Information furnished by Microbridge Technologies is believed to be accurate and reliable. However, no responsibility is assumed by Microbridge Technologies for its use, nor for any infringements of patents or other rights of third parties that may result from its use. Specifications subject to change without notice. No license is granted by implication or otherwise under any patent or patent rights of Microbridge Technologies. Trademarks and registered trademarks are the property of their respective companies.

APPLICATION BRIEF: On the Use of Hoses and/or Filters

Microbridge's MB-LPS1-01-XXXX series differential pressure sensors feature very high flow-through impedance, greater than 10kPa per (ml/s) of flow-through. This makes the sensor virtually equivalent to membrane-type (dead-end type) differential pressure sensors regarding this important aspect of performance for many applications.

Consider, for example, the sensor being used in a shunt configuration, to sense differential pressure across a flow-restrictive baffle in an air duct, thereby inferring measurement of air flow in the duct. To enhance the immunity of the sensor vs. particulate contaminants and humidity, it is desirable to use connection hoses and/or filters, as shown in the figure below. These hoses and/or filters may add flow-impedance to the shunt path, for example up to 1kPa/(ml/s). Due to the high flow-through impedance of the MB-LPS1-01-XXXX series sensors, the change in air flow through the sensor (and therefore the change in the sensor's sensitivity) is small-to-negligible. Even as the filter's characteristics change over time and use, the change will still be small.

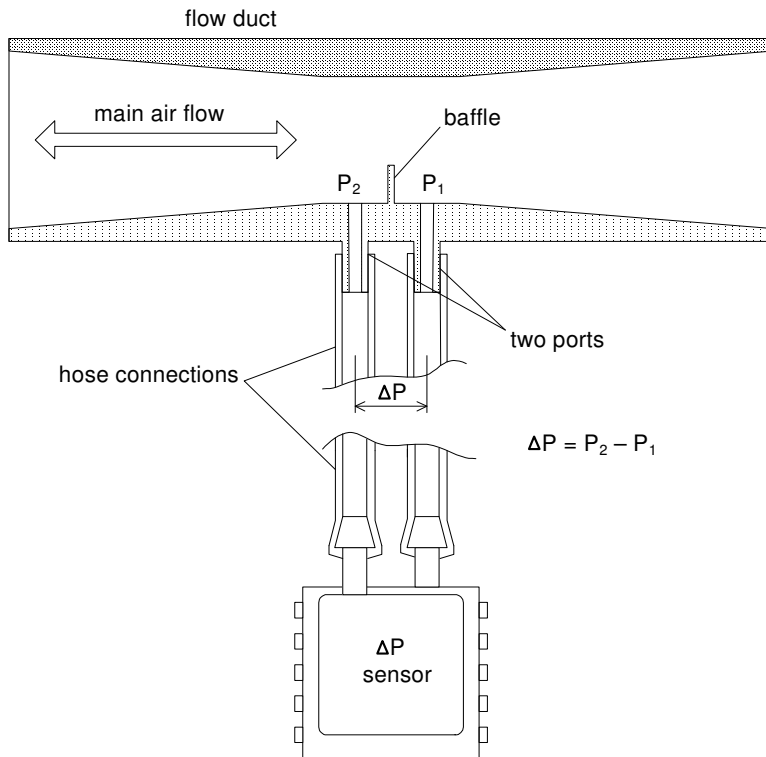

Experimental Verification:

Consider two sensors, where one sensor is connected through 6m of tubing having inner diameter 1/16", as depicted in the diagram below. As seen in the graph, the extra 6m of tubing on one sensor causes a slight time delay due to compressibility of gas in the tubing, but doesn't affect the calibration of the sensor, because the sensor's flow-thru impedance is approximately 100kPa/(ml/s).

→ Calibration is unaffected by long connection hoses.

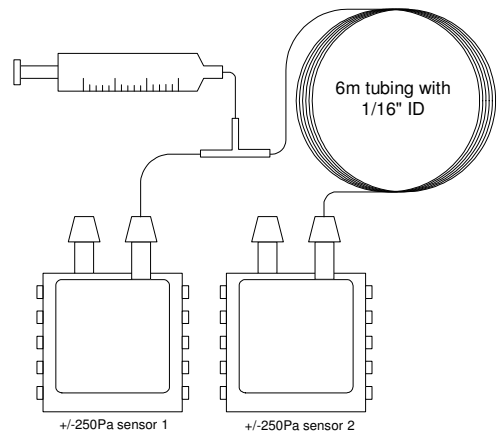
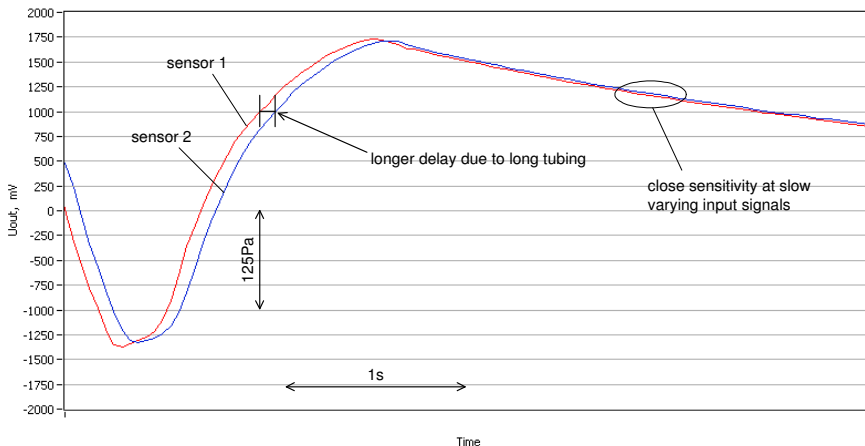

Information furnished by Microbridge Technologies is believed to be accurate and reliable. However, no responsibility is assumed by Microbridge Technologies for its use, nor for any infringements of patents or other rights of third parties that may result from its use. Specifications subject to change without notice. No license is granted by implication or otherwise under any patent or patent rights of Microbridge Technologies. Trademarks and registered trademarks are the property of their respective companies.

APPLICATION BRIEF: Real-Time Sensing of Time-Variations in Absolute Indoor Air Pressure

In order to use this sensor to sense time-variations in absolute indoor air pressure, it is sufficient to connect one flow port to a small closed volume, such that that port is not open to the ambient air pressure → the sensor will sense time-variations in absolute air pressure at the other (open) port.

For example, using the MB-LPS1-01-020B, the sensor's minimum detectable differential pressure is below 0.1Pa, which is roughly 1ppm compared to the ambient indoor air pressure (atmospheric pressure: $\sim 10^5$ Pa). When combined with the sensor's 1-2ms time-response, this is sufficient to sense very small transient changes in indoor air pressure.

For example, if a typical conference room has volume $6\text{m} \times 8\text{m} \times 2\text{m} \approx 100 \text{ m}^3 = 100,000,000 \text{ cm}^3$, then a change in volume of 100 cm^3 corresponds to 1ppm. This would be equivalent to a window having area $2\text{m} \times 1\text{m}$ being displaced at its center by roughly 0.3mm, such as could happen due to a wind gust at the exterior of the building.

Microbridge's MB-LPS1-01-XXXX sensors routinely demonstrate the ability to sense indoor air pressure changes of this magnitude.

APPLICATION BRIEF: Real-Time Sensing of Time-Variations in Altitude

In order to use this sensor to sense time-variations in altitude, it is sufficient to connect one flow port to a small closed volume (such as a few cm^3), such that that port is not open to the ambient air pressure → the sensor will sense time-variations in absolute air pressure at the other (open) port.

Since 1cm of altitude change corresponds to roughly 0.1Pa of absolute pressure change, the sensor can be used to flag sudden changes in altitude, even quite small sudden changes in altitude.

Microbridge's MB-LPS1-01-XXXX sensors routinely demonstrate the ability to sense altitude changes of a few cm magnitude.