

MB-LPS1-01-XXXX5N Series Linear Analog-Conditioned Sensors For Low Differential Air Pressure (Fixed 5V Supply)

GENERAL DESCRIPTION

The MB-LPS1-01-XXXX5N series low-pressure sensors sense differential air (or other non-corrosive gas) pressure, inferring differential pressure from nano-liters per second gas-flow through an integrated air-flow channel having high flow-impedance. The transducer is a MEMS-based thermo-anemometer on a monolithic silicon chip. Rejutor technology combined with CMOS circuitry provides on-chip-integrated analog-only compensation and conditioning electronics. The chips are powered by 5V supply, with fixed (non-ratiometric) output voltage between 0.5V and 4.5V.

FEATURES, BENEFITS

- **Linear Output**
- **High flow-impedance in the range of tens to hundreds of kPa/(ml/s)**
 - Dominates flow-impedance in series (in-line) configurations.
 - Minimizes flow-through in bypass (parallel, shunt) configurations.
 - Allows use of filters and connection hoses without losing calibration.
- **Rejutor-based analog-only on-chip signal conditioning electronics to compensate (Offset, TC-Offset, Span, TC-Span).**

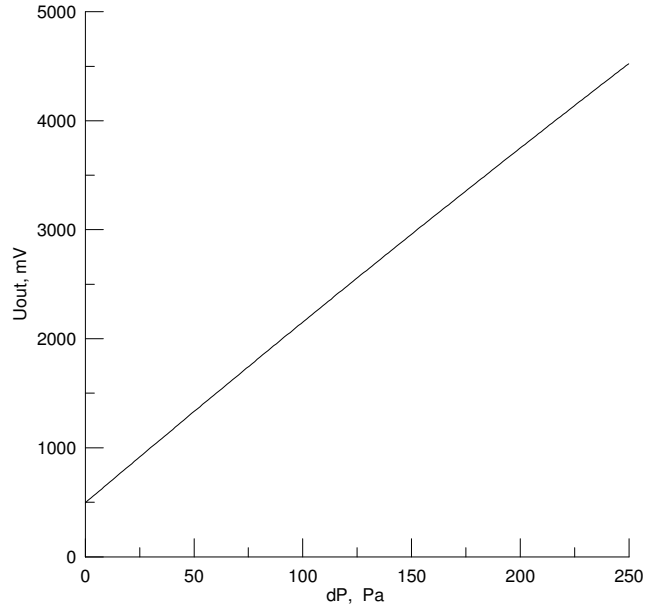

Fig. 1: Typical linear response for MB-LPS1-01 series sensor.
Example: MB-LPS1-01-100U → 1”H₂O, unidirectional.

PRODUCT FAMILY:

MB-LPS1-01-XXXX5N, FOR APPLICATIONS SUCH AS HVAC, REQUIRING LINEAR OUTPUT:

Part Number	Measurement Range* (Full Scale)			Pneumatic Flow-Through Impedance
	Pa	H ₂ O	PSI	
MB-LPS1-01-010B5N	+/-25Pa	+/-0.1”H ₂ O	+/-0.0036PSI	>10kPa/(ml/s)
MB-LPS1-01-010U5N	0...25Pa	0...0.1”H ₂ O	0...0.0036PSI	>10kPa/(ml/s)
MB-LPS1-01-020B5N	+/-50Pa	+/-0.2”H ₂ O	+/-0.0072PSI	>15kPa/(ml/s)
MB-LPS1-01-020U5N	0...50Pa	0...0.2”H ₂ O	0...0.0072PSI	>15kPa/(ml/s)
MB-LPS1-01-100B5N	+/-250Pa	+/-1”H ₂ O	+/-0.036PSI	>50kPa/(ml/s)
MB-LPS1-01-100U5N	0...250Pa	0...1”H ₂ O	0...0.036PSI	>50kPa/(ml/s)
MB-LPS1-01-200B5N	+/-500Pa	+/-2”H ₂ O	+/-0.072PSI	>100kPa/(ml/s)
MB-LPS1-01-200U5N	0...500Pa	0...2”H ₂ O	0...0.072PSI	>100kPa/(ml/s)

- Note: 250Pa = 1.005433”H₂O., which is approximated in this table as 1”H₂O and 0.036PSI. These sensors are calibrated at room temperature according to the number of Pa stated in this table.
- For other full-scale ranges, or asymmetrical full-scale ranges, contact Microbridge.
- Custom units available on request.
- www.mbridgetech.com

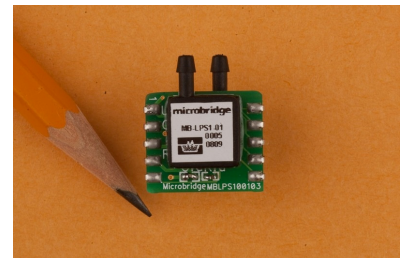

Information furnished by Microbridge Technologies is believed to be accurate and reliable. However, no responsibility is assumed by Microbridge Technologies for its use, nor for any infringements of patents or other rights of third parties that may result from its use. Specifications subject to change without notice. No license is granted by implication or otherwise under any patent or patent rights of Microbridge Technologies. Trademarks and registered trademarks are the property of their respective companies.

**TABLE 1: MB-LPS1-01-XXXX5N SPECIFICATIONS:
LINEAR ANALOG-CONDITIONED LOW DIFFERENTIAL AIR PRESSURE SENSOR**

Characteristic	Specification
Supply Voltage (V_{DD})	$V_{DD} = 5$ VDC (min 4.75V, max 5.25V) (V_{DD} power supply must be externally regulated)
Current consumption	Typ. 3.5 mA (no load)
Output Impedance	Max less than 100 Ω
Minimum output load resistance	5k Ω (less than 1 mA output drive current).
Nominal output voltage (with $V_{DD} = 5$ VDC)	MB-LPS1-01-XXXU5N: 0.5V (at zero-Pressure); 4.5V (at Full-Scale Pressure) MB-LPS1-01-XXXB5N: 0.5V (at Negative Full-Scale Pressure); 2.5V (at zero-Pressure); 4.5V (at Positive Full-Scale Pressure). Output Voltage is fixed (non-ratiometric) vs. Supply Voltage.
Nominal full-scale voltage span (with $V_{DD} = 5$ VDC)	MB-LPS1-01-XXXU5N: +4V MB-LPS1-01-XXXB5N: +/-2V (2V) Full-scale voltage span is fixed (non-ratiometric) vs. Supply Voltage.
Calibrated Offset	less than +/-25mV
Offset Temperature Shift	less than +/-25mV (5°C to 55°C)
Offset Warmup Shift	less than +/-5mV
Pressure Non-Linearity	less than 0.6% of Full-Scale
Differential Pressure Resolution	Typ. 0.1% of Full-Scale (minimum detectable differential pressure)
Span Shift Over Temperature	Typ. +/-1% (5°C to 55°C)
Response Time	Typ. 1-2ms
Total Error	Max. +/-2.5% of Full-Scale (5°C to 55°C)
Burst Pressure	Greater than 5 atmospheres
ESD protection	2000V HBM – JESD22-A114, human body model weakest pin pair testing, all lead combinations, Class 2.
RoHS compliant	

IMMUNITY TO RFI:

Test	Result
Sweep 80MHz - 2.7GHz	<ul style="list-style-type: none"> Less than 0.5% error for any package orientation subjected to 10V/m electric field (by analysis).

STANDARD ALTITUDE CORRECTION:

Variations in ambient atmospheric pressure (caused by elevation with respect to sea level), need to be compensated externally to the sensor, according to a simple mathematical expression:

$$\rightarrow [(True-\Delta P)] = [(Sensor-\Delta P) \times (1.00 \text{ bar}) / (Ambient-Pabs)]$$

where:

True- ΔP : altitude-adjusted differential pressure

Sensor- ΔP : sensor's differential pressure as indicated by the output voltage

Ambient-Pabs : actual ambient absolute pressure (measured in bars)

Note: Units are calibrated such that True- ΔP will equal the Sensor- ΔP when the ambient pressure is 1.00 bar.

PACKAGE AND PINOUT INFORMATION:

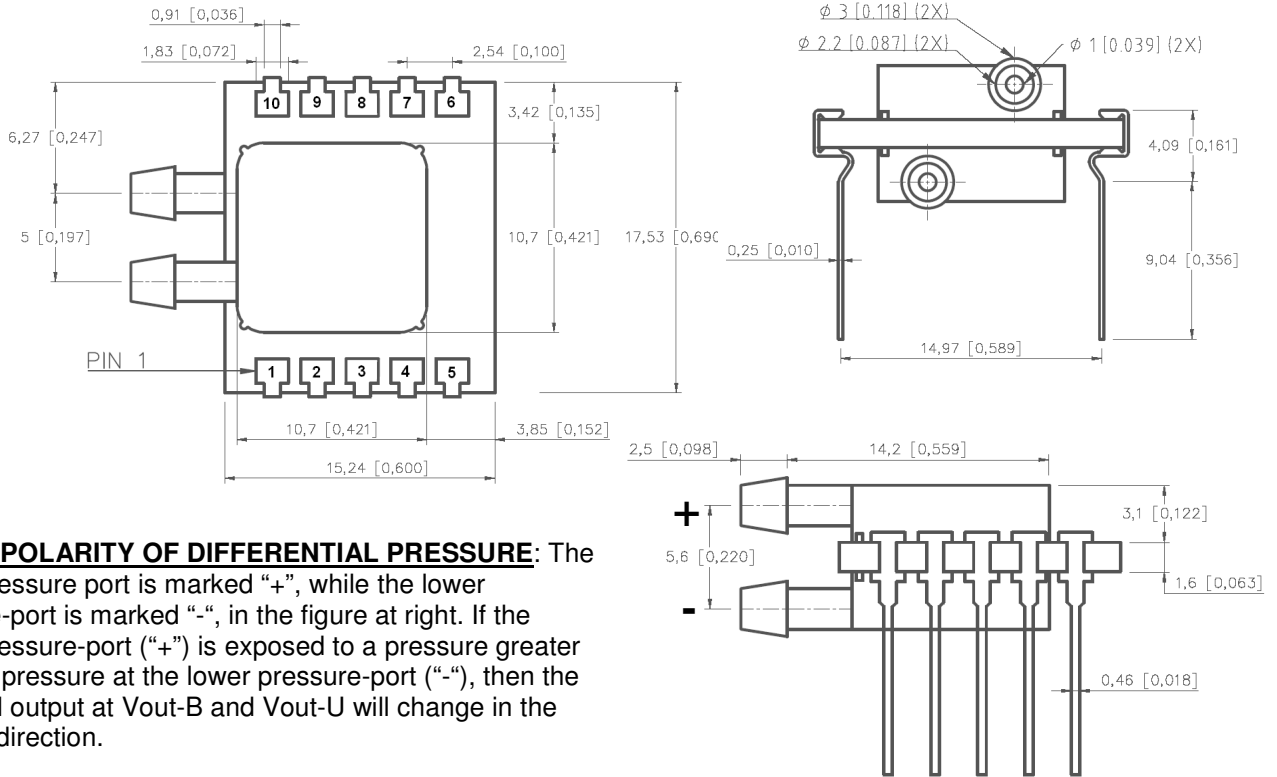

ABOUT POLARITY OF DIFFERENTIAL PRESSURE: The upper pressure port is marked “+”, while the lower pressure-port is marked “-”, in the figure at right. If the upper pressure-port (“+”) is exposed to a pressure greater than the pressure at the lower pressure-port (“-”), then the electrical output at Vout-B and Vout-U will change in the positive direction.

Pin #	Name	Function
1	GND	Main circuit Ground
2	VDD	Main circuit power supply
3	Vout-B	Output voltage for bidirectional-mode sensors (calibrated in MB-LPS1-01-XXXB5N units)
4	Vout-U	Output voltage for unidirectional-mode sensors (calibrated in MB-LPS1-01-XXXU5N units)
		Note: A subset of the above pins are the only pins used during normal functioning of the sensor (GND, VDD and <i>either</i> Vout-B <i>or</i> Vout-U).
5		Pin is grounded (electrically connected to Pin #1) within the packaged sensor.
6		Pin is grounded (electrically connected to Pin #1) within the packaged sensor.
7		Pin is grounded (electrically connected to Pin #1) within the packaged sensor.
8		Pin is grounded (electrically connected to Pin #1) within the packaged sensor.
9		Pin is grounded (electrically connected to Pin #1) within the packaged sensor.
10		Pin is grounded (electrically connected to Pin #1) within the packaged sensor.
		Note: pins # 5 – 10 are used by Microbridge’s adjustment hardware and software, only during adjustment/calibration. These pins are NOT used during normal functioning of the sensor.

RECOMMENDED OUTPUT VOLTAGE FILTERING:

It is recommended for normal usage that the output of the sensor be connected through an RC low-pass filter as shown in the circuit diagram below. The choice of low-pass cutoff frequency can be made according to the desired response-time. Note that this filter is connected during calibration of the sensors, with $R_{filter} \sim 5k\Omega$ and $C_{filter} \sim 100nF$.

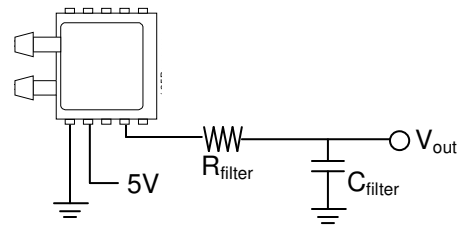

Information furnished by Microbridge Technologies is believed to be accurate and reliable. However, no responsibility is assumed by Microbridge Technologies for its use, nor for any infringements of patents or other rights of third parties that may result from its use. Specifications subject to change without notice. No license is granted by implication or otherwise under any patent or patent rights of Microbridge Technologies. Trademarks and registered trademarks are the property of their respective companies.

PART NUMBER NAMING CONVENTION:

MB - LPS 1 - 01 - 100 B 5 N

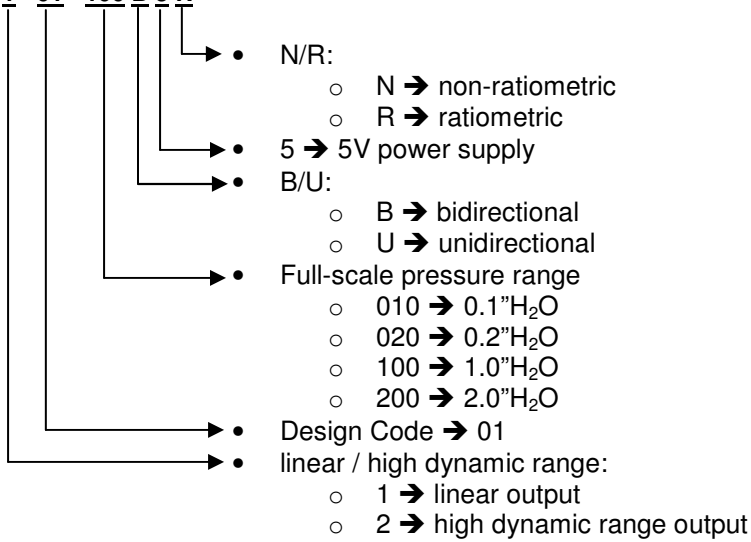

Information furnished by Microbridge Technologies is believed to be accurate and reliable. However, no responsibility is assumed by Microbridge Technologies for its use, nor for any infringements of patents or other rights of third parties that may result from its use. Specifications subject to change without notice. No license is granted by implication or otherwise under any patent or patent rights of Microbridge Technologies. Trademarks and registered trademarks are the property of their respective companies.

APPLICATION BRIEF: On the Use of Hoses and/or Filters

Microbridge's MB-LPS1-01-XXXX series differential pressure sensors feature very high flow-through impedance, greater than 10kPa per (ml/s) of flow-through. This makes the sensor virtually equivalent to membrane-type (dead-end type) differential pressure sensors regarding this important aspect of performance for many applications.

Consider, for example, the sensor being used in a shunt configuration, to sense differential pressure across a flow-restrictive baffle in an air duct, thereby inferring measurement of air flow in the duct. To enhance the immunity of the sensor vs. particulate contaminants and humidity, it is desirable to use connection hoses and/or filters, as shown in the figure below. These hoses and/or filters may add flow-impedance to the shunt path, for example up to 1kPa/(ml/s). Due to the high flow-through impedance of the MB-LPS1-01-XXXX series sensors, the change in air flow through the sensor (and therefore the change in the sensor's sensitivity) is small-to-negligible. Even as the filter's characteristics change over time and use, the change will still be small.

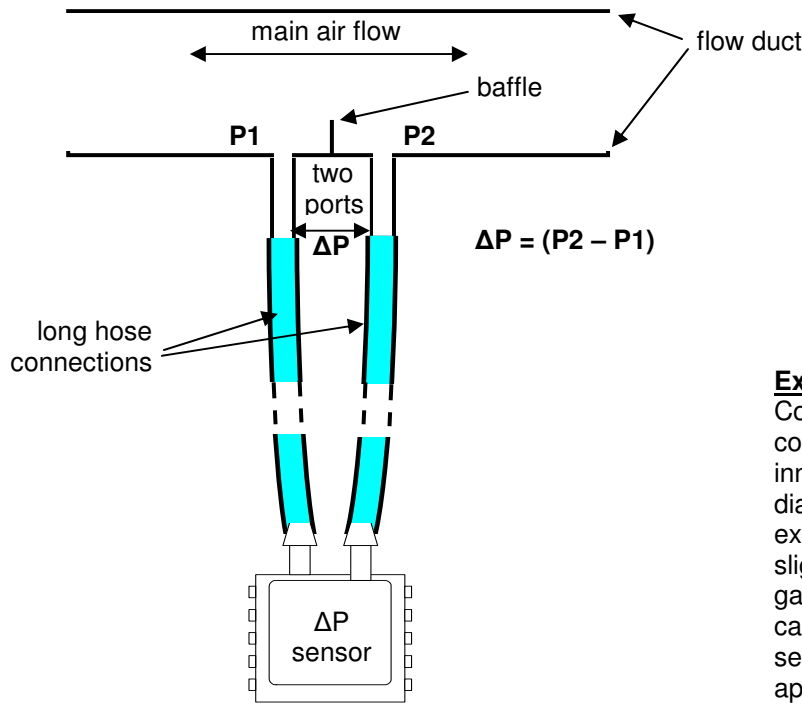

Experimental Verification:

Consider two sensors, where one sensor is connected through 6m of tubing having inner diameter 1/16", as depicted in the diagram below. As seen in the graph, the extra 6m of tubing on one sensor causes a slight time delay due to compressibility of gas in the tubing, but doesn't affect the calibration of the sensor, because the sensor's flow-thru impedance is approximately 100kPa/(ml/s).

→ Calibration is unaffected by long connection hoses.

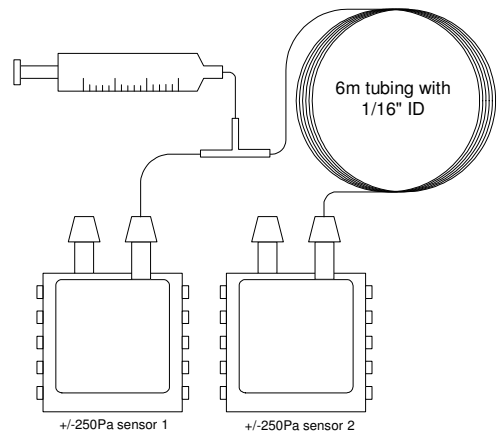
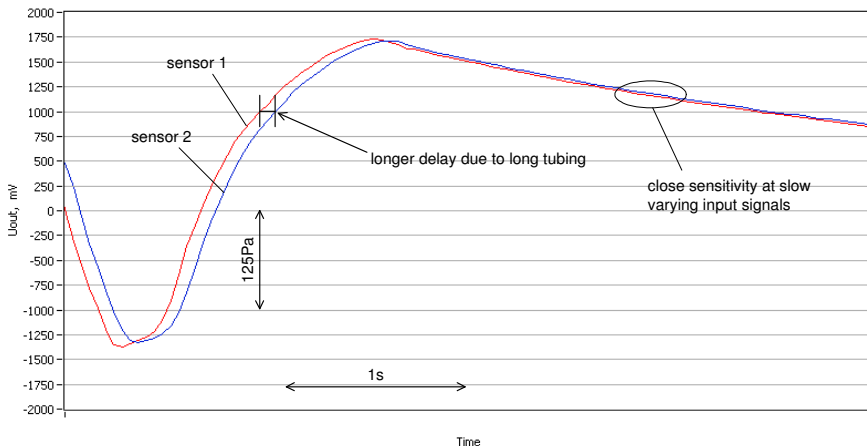

Information furnished by Microbridge Technologies is believed to be accurate and reliable. However, no responsibility is assumed by Microbridge Technologies for its use, nor for any infringements of patents or other rights of third parties that may result from its use. Specifications subject to change without notice. No license is granted by implication or otherwise under any patent or patent rights of Microbridge Technologies. Trademarks and registered trademarks are the property of their respective companies.

APPLICATION BRIEF: Real-Time Sensing of Time-Variations in Absolute Indoor Air Pressure

In order to use this sensor to sense time-variations in absolute indoor air pressure, it is sufficient to connect one flow port to a small closed volume, such that that port is not open to the ambient air pressure → the sensor will sense time-variations in absolute air pressure at the other (open) port.

For example, using the MB-LPS1-01-020B, the sensor's minimum detectable differential pressure is below 0.1Pa, which is roughly 1ppm compared to the ambient indoor air pressure (atmospheric pressure: $\sim 10^5$ Pa). When combined with the sensor's 1-2ms time-response, this is sufficient to sense very small transient changes in indoor air pressure.

For example, if a typical conference room has volume $6\text{m} \times 8\text{m} \times 2\text{m} \approx 100 \text{ m}^3 = 100,000,000 \text{ cm}^3$, then a change in volume of 100 cm^3 corresponds to 1ppm. This would be equivalent to a window having area $2\text{m} \times 1\text{m}$ being displaced at its center by roughly 0.3mm, such as could happen due to a wind gust at the exterior of the building.

Microbridge's MB-LPS1-01-XXXX sensors routinely demonstrate the ability to sense indoor air pressure changes of this magnitude.

APPLICATION BRIEF: Real-Time Sensing of Time-Variations in Altitude

In order to use this sensor to sense time-variations in altitude, it is sufficient to connect one flow port to a small closed volume (such as a few cm^3), such that that port is not open to the ambient air pressure → the sensor will sense time-variations in absolute air pressure at the other (open) port.

Since 1cm of altitude change corresponds to roughly 0.1Pa of absolute pressure change, the sensor can be used to flag sudden changes in altitude, even quite small sudden changes in altitude.

Microbridge's MB-LPS1-01-XXXX sensors routinely demonstrate the ability to sense altitude changes of a few cm magnitude.