

# *Rejutor*<sup>™</sup> Based LM335 Temperature Sensor Calibration

## 1 Introduction

Many types of active and passive sensors use external resistors to establish a set point or compensate for component variations. Traditionally these sensors have been compensated using either laser-trimmed, potentiometers or hand-selected fixed resistors. The *Rejutor* from Microbridge Technologies provides a simple, automated approach to analog compensation for analog problems.

This document describes compensation for LM335 temperature sensor. The LM335 is a diode-based active sensor with a slope of 10mV/K. Due to manufacturing variation, most sensors require offset calibration to provide a direct voltage reading corresponding to the observed temperature.

The *Rejutor* is ideally suited for the resistive adjustment required to set the absolute voltage output of the LM335. One key differentiation achieved using *Rejutors* in temperature sensors and is the ability to change the compensation resistor after final assembly. Temperature sensors can be compensated while immersing in a temperature controlled media. Other precision calibration methods, such as laser trimming, or hand-selected fixed resistors require an additional step to remove the assembly from the environment, apply compensation and retest. It should be obvious that *Rejutors* are more effective and efficient in these applications without compromising precision.

*Rejutors* are electrically adjustable micro-resistors. The resistance of *Rejutors* can be adjusted and precisely fixed within a range at least 30% down from the as-manufactured value. The adjustment process reversibly alters the material properties of the device and the new value is "stored" in the material indefinitely with no external power required. The resistance can be adjusted bi-directionally many times using low-power analog signals under control of Microbridge Technologies' *Rejust-it* Calibration tools.

There are many different *Rejutor*-based compensation and control configurations depending upon how the *Rejutors* are configured in the circuit. This document highlights just a few possibilities. Custom *Rejutor* networks can be developed that include all fixed resistors and *Rejutors* in a single, integrated network. Contact Microbridge Technologies for more information.

## 2 Overview

The LM335 is a well-known temperature sensor, part of a series of precision, easily-calibrated temperature sensors from National Semiconductor. Functionally, the device is a 3-terminal Zener diode with a breakdown voltage directly proportional to absolute temperature at +10 mV/K. Both the *Rejutor* and the LM335 are suitable for operation from -40°C to +100°C.

This application note describes the circuit and *Rejust-it* configuration to calibrate the offset at 20°C (293.15K). The sensor assembly, including *Rejutors*, is submerged in a silicon-oil bath during the

---

<sup>™</sup> *Rejutor* is a trademark of Microbridge Technologies

Information furnished by Microbridge Technologies is believed to be accurate and reliable. However, no responsibility is assumed by Microbridge Technologies for its use, nor for any infringements of patents or other rights of third parties that may result from its use. Specifications subject to change without notice. No license is granted by implication or otherwise under any patent or patent rights of Microbridge Technologies. Trademarks and registered trademarks are the property of their respective companies.

calibration process to ensure temperature stability. The sensor assembly is manufactured on a PCB with an edge connector that fits into a wiring harness in the oil path.

In order to maximize the precision of the adjustment, it was decided to use the differential inputs on the MBK-408 **Rejistor** Calibration Tool. The differential inputs have a combined gain of 576V/V allowing high precision adjustment. In order to accommodate this configuration, a reference signal is required. The MBK-408 adjusts the resistance of the **Rejistor** until the difference between the reference signal and the circuit under test is zero. The reference, in this case 2.9315V, can be supplied from a stable voltage source or from a “golden reference” sensor immersed in the oil bath.

The **Rejistor** is the only available precision resistor that can be adjusted while the assembly is immersed in a silicon-oil bath. Other precision trimming methods, such as, laser trimming thick-film resistors, turning the screw on a potentiometer or installing high-precision fixed-resistors require an additional step to remove the sensor assembly from the silicon-oil bath, make the physical adjustment, then return to the bath and verify accuracy.

### 3 Circuit Description

The LM335 with **Rejistor** circuit is shown in Figure 1 (the circuit has been simplified for clarity and does not include, for example, filter capacitors and protection diodes). To minimize board real-estate, a **Rejistor** packaged in a 16-pin QFN is used.

The MBD-103-AS **Rejistor** divider (order number 1112) with a 1:1 ratio between Rj1 and Rj2 is used for this application. The as-manufactured resistance of the **Rejistors** is 10K $\Omega$ . The output voltage for the LM335 is nominally centered about the target value (that is, the target value is approximately the midpoint of the resistor pair).

#### 3.1 Differential Adjustment

This example uses differential voltage adjustment mode with Rejust-it to adjust the **Rejistors** to achieve the desired output voltage. It should be stressed that one of the advantages of the **Rejistor** is the ability to perform in-circuit adjustment. This means the adjustment is made to the resistance of the **Rejistors** such that the desired output voltage is achieved. The actual resistance value of the **Rejistors** is less important than achieving the required voltage target for the sensor.

In a typical application, the circuit would be manufactured with a break-away 7-pin edge connector that interfaces to a test jig. The test jig is hardwired to the reference source and be capable of being immersed (or partially immersed) in the temperature stabilizing oil bath. The test-jig connects the unit under test to the MBK-408A **Rejistor** Calibration Tool.

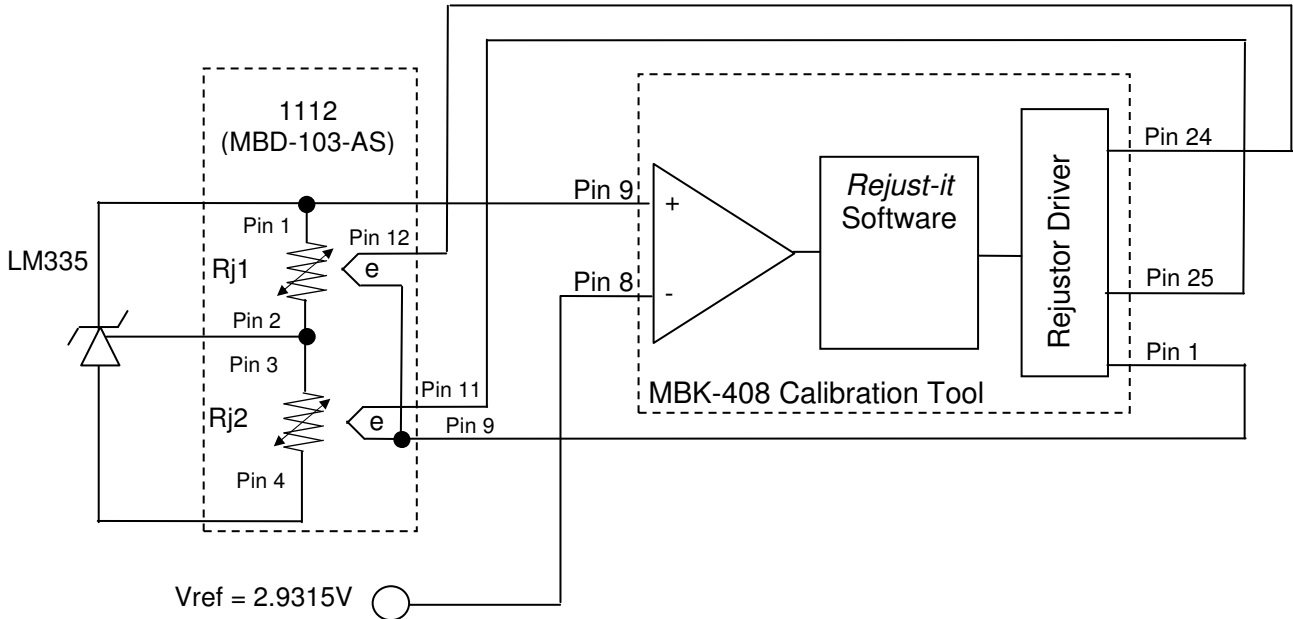

Figure 1: LM335 Reference Circuit with Rejistor Calibration Tool

### 3.2 Circuit Precision

The output of the sensor connects to analog input on the non-inverting pin of number CH0 (Pin 9) on the 26-pin connector of the MBK408A **Rejistor** Calibration tool. The reference voltage, from either an external voltage source or from a golden-reference sensor, is connected to the inverting input on CH0 (Pin 8).

The differential input amplifier on Channel 0 measures the difference between the output of the sensor under test and the reference, with the goal of achieving zero voltage differential between the two. The first amplification stage in the MBK-408A has a gain of  $48^{V/V}$ . This stage is used for coarse adjustment of the differential inputs. The second stage on Channel 1 has a gain of  $12^{V/V}$  for a combined gain through both stages of  $576^{V/V}$ . This allows fine tuning of the differential.

Given that 1-bit on the ADC inside the MBK-408 is approximately equal to 5mV, the minimum resolution achievable with this configuration is  $8.5\mu V$ . Considering the output of the LM335, this corresponds to a temperature accuracy of 85mK (or 0.085K). Obviously with this level of precision, it is important to accurately stabilize the temperature of the sensor during the adjustment process.

### 3.3 Hardware Configuration

The interconnection between the MBK-408A **Rejistor** Calibration Tool, the Temperature Sensor and the Reference Voltage is shown in Figure 1. Details of the sensor circuit have been omitted for clarity.

The 16-pin MBD-103-AS **Rejistor** connects to the sensor on one side of the package and to the Calibration Tool on the other side. Pin 2 and pin 3 must be connected together outside the package. The four connections between the sensor circuit and the MBK-408 Calibration Tool can be removed once calibration is complete. These connections are routed to the 26-pin D-connector for connection to the MBK-408A. One connector is required for each sensor being calibrated.

### 3.4 MBK-408A to LM335 Wiring Description

Table 1: MBK-408 Wiring Harness

MBK-408 DB-26 Connector pin #	Function	Description
9	+IN	Reference voltage
8	-IN	Vin (from UUT)
24	DAC 2	Rj1 Adjust
25	DAC 1	Rj2 Adjust
3	AGND	Ground
1	GND = HGND	Adjust Ground

### 3.5 Reference Voltage for Differential Adjustment

The temperature sensors are calibrated against a known good source or “Golden Standard”. *Rejust-it* trims the **Rejustors** until the difference between sensor output and the reference voltage is  $0 \pm 0.01\text{mV}$  depending on the noise exhibited by the system.

Any error in the precision of the voltage reference is cumulative with the **Rejustor** calibration uncertainty.

## 4 Using Rejust-it

The following steps outline the process to use Rejust-it software with the **Rejustor** Calibration tool. The Circuit Configuration Editor is used to develop the transfer function, which describes the circuit configuration and behavior of the circuit. The transfer function is developed only once for each unique circuit configuration. Rejust-it is used to adjust the resistance of the **Rejustor** to calibrate each sensor.

### 4.1 Circuit Configuration Editor

The Circuit Configuration Editor is provided with the Rejust-it software package. It is used to define the connections between the circuit under test, in this case the LM335, and the MBK-408A.

#### 4.1.1 Develop the Transfer Function

The transfer function relates changes in the voltage at the LM335 (input function) to change in the resistance of the **Rejustor** (output function) at a constant temperature. The transfer function was determined experimentally by placing a 90K $\Omega$ , 40K $\Omega$  and 23K $\Omega$  resistor in parallel with each **Rejustor** and measuring the corresponding change in sensor voltage. These parallel resistors represent 10%, 20% and 30% decrease in the effective resistance, respectively.

The transfer function represents the approximate relationship between input and output, as discussed. Because a high-degree of precision is not required for the transfer function<sup>1</sup>, the

<sup>1</sup> Rejust-it uses an adaptive algorithm to adjust the resistance to achieve the desired output voltage. The transfer function provides a guide and is used to set error flags within Rejust-it.

experiment was conducted on a lab-bench with no provision for change in temperature at the sensor. The results of the experiment are shown in Table 2. Notice that decreasing the resistance Rj1 results in an increase in Vout. This polarity difference is reflected in the sign on delta Vout, relative to the fixed voltage.

**Table 2: LM335 Application - Transfer Function, Experimental Results**

Rj1 (Ω)	RJ2 (Ω)	Vout (V)	Delta Vout (mV)
10K	10K	2.98	0
9K	10K	3.01	30
8K	10K	3.04	60
7K	10K	3.07	90
10K	9K	2.95	-30
10K	8K	2.92	-60
10K	7K	2.89	-90

Note: Most **Rejistor** divider applications have one **Rejistor** that will increase the output and one that will decrease the output of the circuit as the resistance is adjusted down.

A Screen-shot of the Circuit Configuration Editor is shown Figure 2.

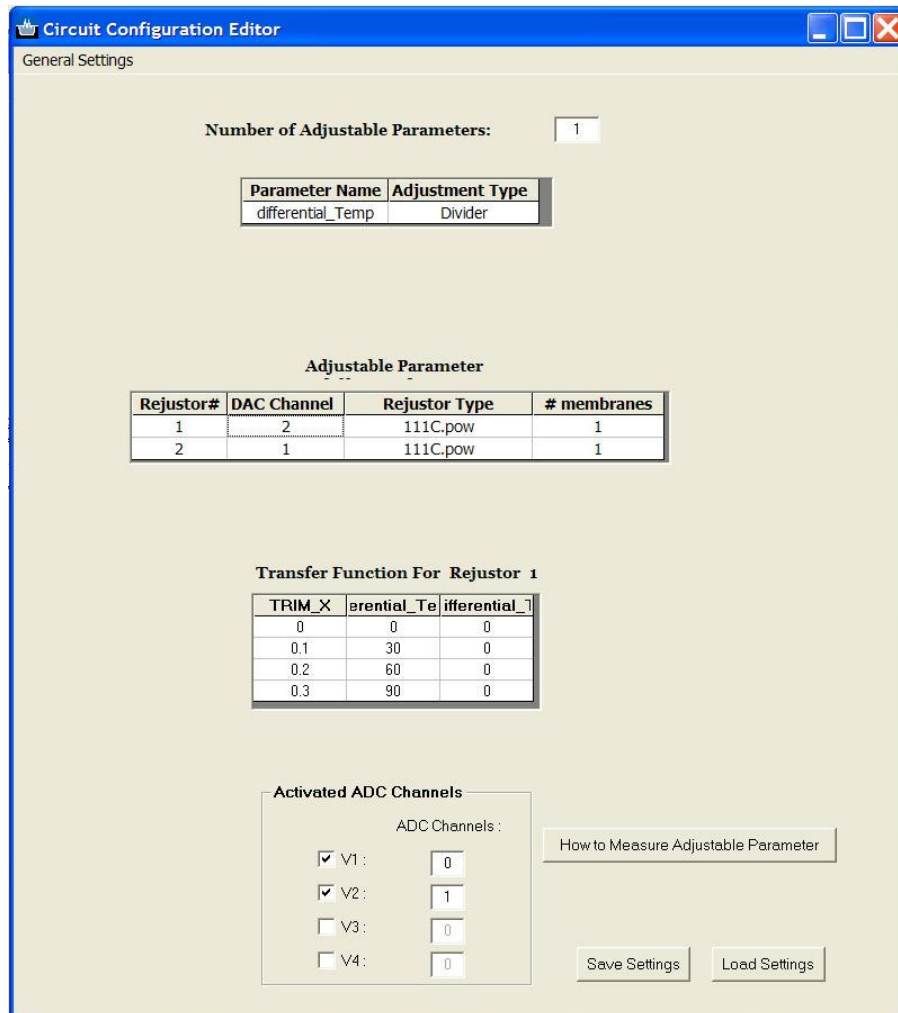

**Figure 2: Configuration Editor - for Rj1**

### 4.1.2 Define the Adjustable Parameter

Two adjustable parameter definitions are needed for this configuration. The first, for coarse adjustment, uses the Channel 0 amplifier in the MBK-408A **Rejutor** Calibration tool, with a gain of  $48^{V/V}$ . The second, for fine-adjustment uses Channel 1 with a gain of  $576^{V/V}$ . Refer to the Conditional Adjustable Parameter Definition in Section 5.8.3 of the MBK-408A User Manual.

The circuit configuration editor allows conditional adjustment. The following conditions apply:

$$\begin{array}{ll} -8000 < V2 > +8000 & \text{use V1} \\ \text{Or,} & \\ -8000 \geq V2 \leq +8000 & \text{use V2} \end{array}$$

That is, if the voltage on Channel 1 (the  $576^{V/V}$  amplifier on V2) is more negative than  $-8000\text{mV}$ , or greater than  $+8000\text{mV}$ , use Channel 0 (the  $48^{V/V}$  amplifier on V1) because the output of Channel 1 is close to saturation. Otherwise, if Channel 1 is not close to saturation, use Channel 1 for the highest precision. A screen shot for Condition 1 is shown in Figure 3, below. Note, both conditions must be defined about the same reference (in this case V2) to ensure there is no ambiguous area within the definition.

#### 4.1.2.1 Condition 0 – Coarse Adjustment

$V_{out}$  at the ADC within the MBK-408A observed on Channel 0 includes the  $48^{V/V}$  gain. To reflect the actual differential, the signal must be divided by 48. In other words,

$$V_{out} = \frac{V1}{48}$$

Recall the equation that describes the input signal mapping has the form:

$$\text{Parameter} = \frac{A0 + A1 \times V1 + A2 \times V2 + A3 \times V3 + A4 \times V4}{B0 + B1 \times V1 + B2 \times V2 + B3 \times V3 + B4 \times V4}$$

Therefore we can simplify the parameters to  $A1 = 1$  and  $B0 = 48$ . The complete definition for condition 1, with the measurement on Channel 0, is shown in Figure 3.

#### 4.1.2.2 Condition 1 – Fine Adjustment

$V_{out}$  at the ADC within the MBK-408A observed on Channel 1 includes the  $576^{V/V}$  gain. To reflect the actual differential, the signal must be divided by 576. In other words,

$$V_{out} = \frac{V2}{576}$$

Therefore we can simplify the parameters to  $A2 = 1$  and  $B0 = 576$ .

**Adjustable Parameter**

Parameter

Voltage :  V1  V2

Conditional

Condition1  Condition2  Condition3

$$\text{Adjustable parameter} = \frac{A0 + A1 * V1 + A2 * V2 + A3 * V3 + A4 * V4}{B0 + B1 * V1 + B2 * V2 + B3 * V3 + B4 * V4}$$

**Voltage Conditions**

Voltage >= 0

Voltage > 8000

Voltage <= 0

Voltage < -8000

AND  OR

**Coefficients**

A0: 0 B0: 48

A1: 1 B1: 0

A2: 0 B2: 0

A3: 0 B3: 0

A4: 0 B4: 0

Measure Adjustable Parameter

Apply Coefficients

OK

Figure 3: Condition 1

The configuration file must be stored in the APPLICATIONS CIRCUITS directory within the Rejust-it folder.

## 5 Rejust-it Temperature Sensor Calibration

Calibration of the LM335 Temperature is performed with *Rejust-it* as described below. The process assumes the configuration file has been created and is stored in the APPLICATION CIRCUITS directory.

The calibration process further assumes the circuit has been assembled as shown in Figure 1, the reference is supplied to the MBK-408A and that both the temperature sensor and the reference are stable at the calibration temperature.

The temperature at which calibration is performed may require some experimentation. The LM335 is slightly non-linear, as a result, the calibrated unit does not track at exactly 10mV/K. Generally the offset should be adjusted about mid-range in the operating temperature to minimize error.

### 5.1 Launch Rejust-it, Load Configuration File

- Navigate to the installation directory (default is C:\Program Files\Rejust\_It35)
- Double-Click **Rejust-it** to launch the application on the host computer
- Load the configuration file for LM335 Calibration (created in Section 4)

## 5.2 Check Connections

- Turn on the MBK-408A and apply power to the test circuit
- Press **Measure** in the Divider tab to measure the voltage difference between the sensor and the reference signal.
  - Ensure the measurement is consistent with your expectations. The expected value is normally less than  $\pm 100\text{mV}$
  - The Measure function tests the input connections to the MBK-408 **Rejistor** Calibration Tool. If the measurement is not in the acceptable range, please debug the test circuit and the connections to the MBK-408 input amplifier before proceeding. Also verify the Voltage Reference is on.
- In the Check Connections portion, select first DAC1, then DAC2 and press Check Connections. The example in Figure 4 shows the connection for DAC1. Notice the output voltage increases when the check is measured on DAC1. This is because the Check Connections pulse causes the resistance of the **Rejistor** to increase. This results in an increase in the output voltage differential between the sensor and the reference.

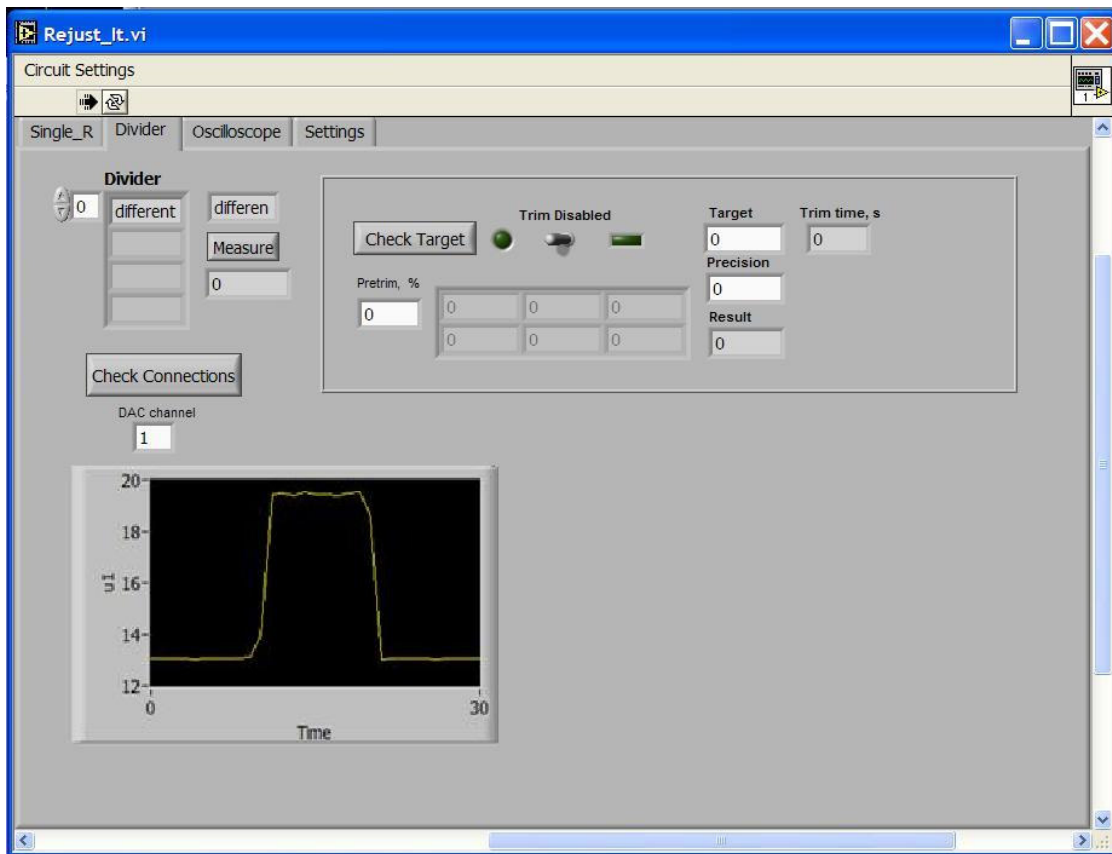

Figure 4: Check Connections, DAC1 (Rj2)

### 5.3 Calibrate the Temperature Sensor

When the Check connections test pass, the measurement is within expected value and the temperature of the sensor (and reference, if applicable) have stabilized. Set the target to 0 and press the TRIM button. The sensor will calibrate within 2-seconds.

- Set the **Target** to 0
- Toggle the **Disable Trim/ Enable Trim** switch to **Enable Trim**
- Press **OK** to start trimming
- Use the **Measure** function to verify the temperature sensor has been calibrated to a difference of 0mV.

This configuration can easily achieve precision <0.01K if the temperature of the sensor is well controlled.

## 6 Summary

This application note describes the process for calibrating LM335 Temperature sensors using the 10KΩ dual **Rejistor** from Microbridge. An external reference is used for the adjustment. The unit-under-test is adjusted to match the output voltage of the reference. This calibration process provides the highest precision and traceability to a reference. Because the achievable precision is high, it is necessary to stabilize the temperature of the sensor during adjustment. **Rejistors** are the only adjustable resistor technology that is adjusted electrically, making them ideal for adjustment within the temperature stabilizing environment (for example an oil bath).

A configuration file was created that allows both coarse and fine adjustment – maximizing the functionality within the MBK-408A **Rejistor** Calibration tool. The adjustment, which is controlled by LabVIEW-based Rejust-it software, typically requires 2-seconds to achieve <0.01K precision, providing electrical noise is well controlled within the design and test fixture.

**Rejistors** provide good long-term stability and require no stand-by power or boot-up period during operation. The resistance of the **Rejistor** is physically altered within the poly-silicon to produce a new electrical resistance.

This white paper focuses on one of the many applications for small, precision adjustment using the **Rejistor**. Adjust your design!